



VRLA Rechargeable Battery

BPS230-12 (BPS230-12FR)

FEATURES

- Maintenance free(no water topping-up required)
- No free acid(Non-spillable battery)
- Can be used in any orientation(excluding used inverted)
- Flame-arrestor is installed to ensure safety
- Carry handles for easy installation
- Absorbent Glass Mat technology for efficient gas recombination

APPLICATION

- UPS
- Telecom

SPECIFICATIONS

Nominal Voltage	12V	
Nominal Capacity	20 Hour Rate (11.50A, 10.5V)	230.0 Ah
	10 Hour Rate (21.85A, 10.5V)	218.5 Ah
	5 Hour Rate (39.10A, 10.5V)	195.5 Ah
	1 Hour Rate (138.00A,9.3V)	138.0 Ah
Approx. Weight	72.5Kg(159.8lbs.)	
Terminals	B9 (Fitting M8 bolt & nut) I3 is optional	
Max. Discharge Current	800 A (5 sec.)	
Max. Charge Current	69 A	
Operating Temperature Range	Charge	0°C~40°C(32°F~104°F)
	Discharge	-20°C~50°C(-4°F~122°F)
	Storage	-20°C~40°C(-4°F~104°F)
Self Discharge	< 3% per month (25°C)	
Internal Resistance	≤ 2.5m Ω (Fully Charged)	



CONTAINER MATERIAL

- BPS230-12:
ABS: UL 94-HB (Dark gray color)
- BPS230-12FR:
ABS: UL 94-V0 (Light gray color)

 ISO 9001	 ISO14001
 MH19884 UL	 C4M20310-2474-E-16 CE
<ul style="list-style-type: none"> ● IEC60896 ● GB/T 19638 	<ul style="list-style-type: none"> ● JIS C 8704

OUTER DIMENSIONS mm(inch)

Length (L)	Width (W)	Container Height (H)	Total Height (TH)
522±2.0(20.55±0.08)	240±2.0(9.45±0.08)	216±2.0(8.50±0.08)	240±2.0(9.45±0.08)

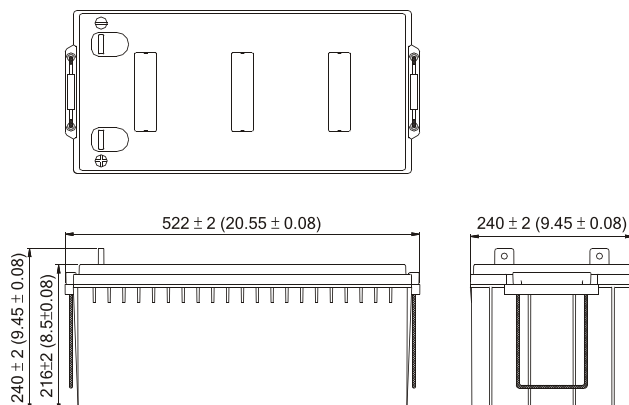

TERMINAL TYPE

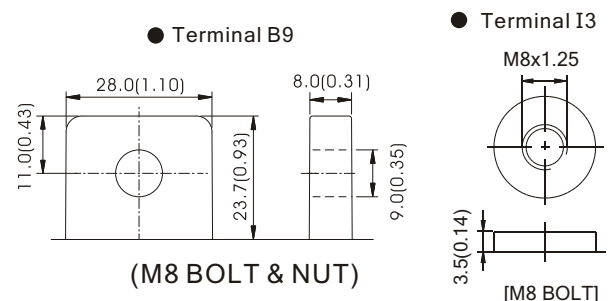

Terminal Hardware Initial Torque: B9,I3(10.0Nm±5%)

BPS230-12 (BPS230-12FR) discharge characteristics (25°C /77°F)

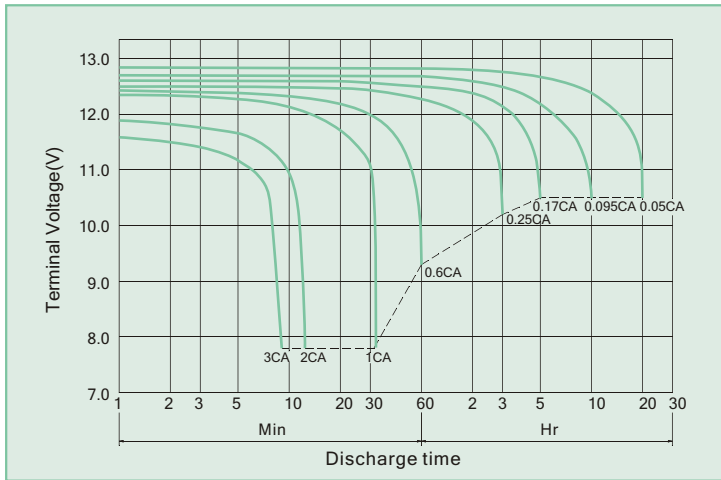

Battery Charging Characteristics

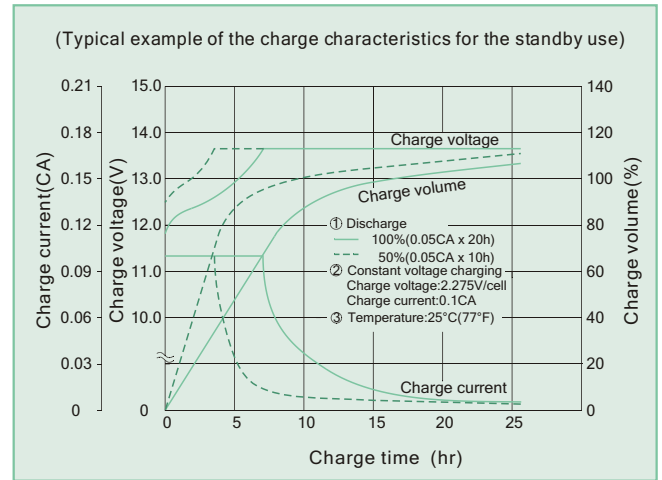

Charging Procedure

Application	Charging method	Charging Voltage at 25°C (V/cell)	Temperature compensation coefficient of charging voltage (mV/°C /cell)	Max. charging current (CA)	Charging time 0.1CA, 25°C (h)		Temp (°C)
					100% discharge	50% discharge	
For standby power Source	Constant voltage & Constant current charging (with current restriction)	2.25~2.30	-3	0.3	24	20	0~40 (32~104°F)
For cycle service		2.40~2.50	-4	0.3	16	10	

Effect Of Temperature On Long Term Float Life

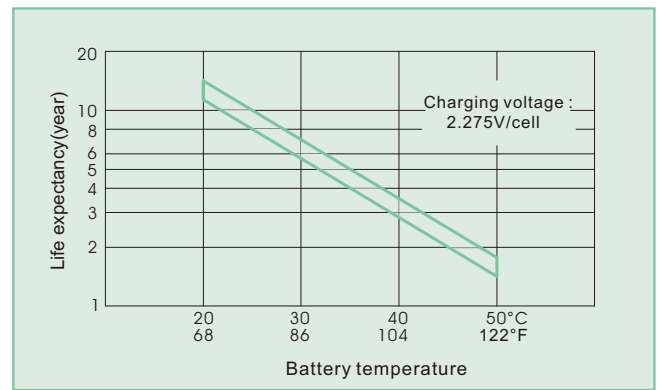

Constant power discharge characteristics at 25 °C/77 °F Unit: W

F.V. (V/cell) \ Discharge Time	15 Min	30 Min	1 Hr	3 Hr	5 Hr	10 Hr	20 Hr
1.80V	4283	2918	1674	670.3	462.3	258.3	135.9
1.75V	4480	3029	1724	683.8	469.2	262.2	138.0
1.70V	4618	3098	1755	690.0	471.8	263.5	138.7
1.65V	4724	3141	1776	694.9	473.5	264.2	139.1
1.60V	4819	3174	1794	698.9	474.8	264.2	139.1

Constant current discharge characteristics at 25 °C/77 °F Unit: A

F.V. (V/cell) \ Discharge Time	15 Min	30 Min	1 Hr	3 Hr	5 Hr	10 Hr	20 Hr
1.80V	372.4	247.3	140.7	55.86	38.53	21.52	11.32
1.75V	389.6	256.7	144.9	56.98	39.10	21.85	11.50
1.70V	401.6	262.6	147.5	57.50	39.32	21.96	11.55
1.65V	410.8	266.2	149.3	57.91	39.46	22.02	11.59
1.60V	419.0	269.0	150.8	58.24	39.56	22.02	11.59

All data shall be changed without prior notice, BB reserves the right to explain and update the information contained hereinto.